



Centre for Development of Imaging Technology (C-DIT)
Chithranjali Hills, Thiruvallom, Tvpm-695 027
Phone: 2380910/ 912/ 895 Fax: 2380681

Tender

Extract of Public Notice:



Centre for Development of Imaging Technology (C-DIT)
Chithranjali Hills, Thiruvallom, Tvpm-695 027
Phone: 2380910/ 912/ 895 Fax: 2380681

NOTICE FOR BIDS

No. C-DIT/3/SET-CHU/08/T 266 Dated 20.12.08

C-DIT invites sealed competitive bids for the supply of PCs, Software's, Digital SLR Cameras, Lens & for fabrication of Lighting units for a project of its Software Engineering Team. Full details are given in our website: www.cdit.org. Last date for receipt of sealed tenders along with EMD @ 2% of the quoted value is 02.01.09 at 11AM. The tenders will be opened at 11.30AM, same day.

Sd/ **REGISTRAR**

Tender Number: No. C-DIT/3/SET-CHU/08/T 266 Dated 20.12.08

**Supply & Installation of Desktop PC's, Software's, Digital SLR
Cameras, Lens & for fabrication of Lighting units:**

Terms & Conditions and detailed specifications:

Detailed Specifications:

Sl.No	Item	Specification	Qty Reqd
01	Desktop Computers	Intel Core2Duo 2.0 GHz or above with 2MB L2 Cache, 800 MHz FSB, Intel Chipset Motherboard, 1 GB DDR2 RAM or above, 120GB SATA HDD (&200 rpm) or above, DVD R/W, Integrated Graphics, Optical Scroll Mouse, Keyboard, 10/100 Mbps Integrated LAN, 15" TFT Monitor & 3 yr onsite Warranty	4 Nos
02	Digital SLR Cameras	Digital SLR Camera-Body only with CMOS Sensor, Min.Resolution-12 Megapixels, Image sensor-Full frame (35.8x23.9 or above), Shutter speed-1/8000-30sec, USB Connectivity & remote Shooting	4 Nos
03	Lens	Focal Length of 35mm, with a minimum focusing distance of 25cm	4 Nos
04	Planetary Lighting unit with Camera Mounts	As per Design, using GI Pipes/ Frame/ Sheet & Novopan Board	4 Nos
05	Software's	Visual Studio 2008 Professional edition & SQL Server 2008 standard edition	1 no. each

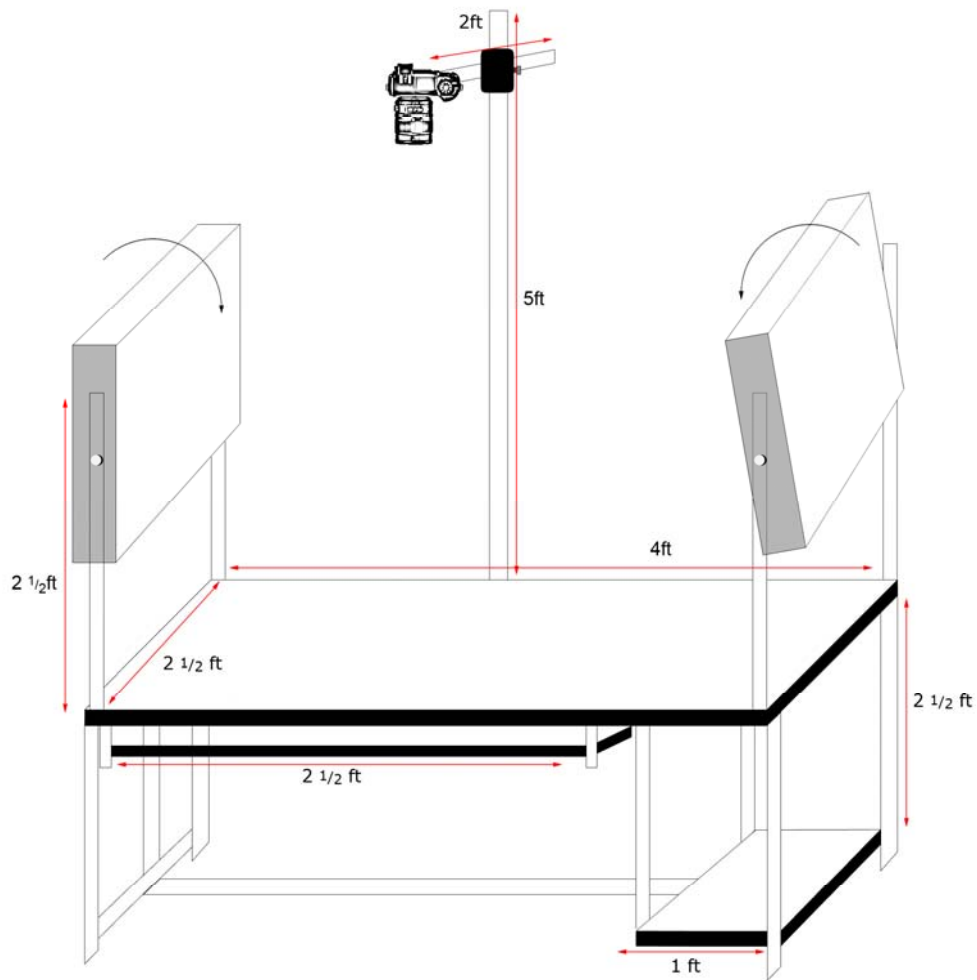

Scope of work: Supply and Installation of Desktop Computers , Software's, Digital SLR Cameras, Lens & for fabrication of Lighting units as per the specifications, terms and conditions given below and terms stipulated in the Purchase Order, at Site.

Site: State Archives, Tvpm.

Service facility: For Computers & Digital Cameras, the Supplier should have adequate service facility in Thiruvananthapuram with competent personnel to coordinate and to give effective and prompt after sales support within a reasonable time frame.

Delivery time: The delivery should be completed within 15 days from the date of receipt of confirmed purchase order.

Terms & Conditions

1. **EMD @ 2%** of the quoted price should accompany the price offer, in the form of Bank Guarantee (Format given below as Annexure-1))/ Demand Draft/ Bankers Cheque favouring Registrar, C-DIT payable at Thiruvananthapuram and should be valid for minimum 1 year period. The EMD of unsuccessful tenderers will be returned as soon as the formalities are completed after award, and the EMD of the successful tenderer will be released when the successful tenderer has executed an agreement (as in Annexure-iii) and deposited Security Deposit/ Performance Guarantee. (EMD is compulsory) No interest will be payable on the EMD/BG. The EMD/BG submitted by all tenderers are liable to be forfeited in case the tenderer withdraws his tender or enhances the prices during the validity period. 2. **Security Deposit/ Performance Guarantee:** The successful tenderer shall, within a week from the date of intimation of the acceptance of his/their tender, submit a security deposit for an amount equivalent to 5 % of the value of the contract for the faithful performance of the contract and for guaranteeing the performance of the equipment in the form of demand draft/fixed deposit receipt or bank guarantee as per the proforma attached as Annexure II (The Bank Guarantee shall be from a Nationalised Bank/Scheduled Bank. The SD will be released only after one year from the date of Installation of the equipment. 3. **Deviation in Delivery Schedule:** Any deviation in agreed delivery schedule would attract penalty as per C-DIT's Procurement Policy. If the delivery at site is not made within the scheduled dates, liquidated damages, not penalty amounting to ½ % of contract value shall be levied from the supplier per week of delay or part thereof for delay up to 15 days from the scheduled date of supply subject to a maximum of 5% of contract value and for further delay, tenderer should be prepared to forfeit the SD. Further in case of delays beyond a grace period of 15 days, C-DIT reserves the right

to cancel the order without further notice

4. Agreement: An agreement to be entered in to for ensuring after sales support during the warranty period.

5. Authority: The authority for the acceptance of the tenders rests exclusively with the C-DIT. The C-DIT does not undertake to accept the lowest or any particular tender or to assign any reason whatsoever for the rejection of any tender.

6. Payment terms: The following terms of payment shall be applicable for the contract – In the case of Indigenous supply- 100 % payment within 30 days time after successful installation of the equipments at site or in the case of Import- 100% irrevocable L/C payment in advance on receipt of order acknowledgement from the Principal Company

7. Default in delivery schedule: In case the tenderer/supplier fails to supply any of the items ordered within the time provided for delivery, or the supplier commits any breach of the contract, it shall be lawful for the society to arrange for the purchase of the said items and things from elsewhere or to cancel the contract at the risk and cost of the supplier.

8. Other conditions:

- a) The tenderer /Supplier shall undertake to supply materials according to the relevant national/ international standards/specifications. No representation of enhancement of rates once accepted will be considered.
- b). Bids will be accepted from bonafide manufactures or their direct authorised dealers only who have supplied at least one such system specified above. If the bidder is the original manufacturer, he should be sourcing the components /part systems. If dealer, the valid authorisation/dealership certificate should be produced.
- c) The bidders, for the maintenance of supplied system should have adequate service facility in Thiruvananthapuram.
- d). The price quoted should be valid for minimum 3 months time, from the date of receipt of initial confirmed order.
- e). In the case of Imports, the price should be quoted in FOB (shipment port).
- f). Any deviation in the specifications in comparison with the requirement should be clearly brought to the notice of C-DIT.
- g). Warranty of the equipment: 3 year onsite for Computers, 1 year for the Camera & 1 year for fabrication unit from the date of Installation.

Sd/ REGISTRAR, C-DIT

Dated 20.12.2008

Annexures:

ANNEXURE I
PROFORMA FOR BANK GUARANTEE IN LIEU OF EARNEST MONEY
DEPOSIT

(To be stamped in accordance with Stamp Act)

Bank Guarantee No.

Date :

Ref :-

To

Centre for Development of Imaging Technology
Chitranjali Hills
Thiruvallom, Thiruvananthapuram - 695 027 (India)

Dear Sirs,

WHEREAS in response to your Tender Notification No. due on* M/s having its registered office at (hereinafter called "Tenderer") wish to participate in said tender for as specified AND

WHEREAS an irrevocable bank guarantee in lieu of cash deposit for an amount of valid for*** days from is required to be submitted by the Tenderer as a condition precedent for participation in the said tender, which amount is liable to be

forfeited on the happening of any contingencies mentioned in the Tender documents.

We, the at having our Head Office at (hereinafter referred to as "the Bank") do hereby undertake to pay immediately on demand to the Centre for Development of Imaging Technology, Chitranjali Hills, Thiruvallom, Thiruvananthapuram - 27 (hereinafter called C-DIT) an amount of Rs. (on words and figures) without any reservation, protest, demur and recourse. Any such demand made by C-DIT shall be binding on us irrespective any dispute or difference raised by the Tenderer.

This guarantee shall be irrevocable and shall remain valid upto^{***}..... If any further extension is remitted the same shall be extended to such required period (not exceeding one year) on receiving instructions from M/s. On whose behalf this guarantee is issued.

In witness whereof the Bank, through its authorised Officer, has set its hand and stamp on this Day of Month 200 at

WITNESS
.....

(Signature)
(Name)

(Signature)
.....

Designation with
Bank stamp

(Name)
No :
.....

Power of Attorney
Date

(Official Address)

Notes :- The stamp paper is to be purchased in the name of
Executing Bank

* This date shall be due date of tender opening

** The amount shall be 2% of the bid price

*** The validity date shall be 210 days from the due date of bid opening

ANNEXURE - II
PROFORMA FOR PERFORMANCE GUARANTEE
(To be stamped in accordance with Stamp Act)

Bank Guarantee No.

Date :

Ref

To

Centre for Development of Imaging Technology
Chitranjali Hills
Thiruvallom, Trivandrum 695 027

Dear Sirs,

In consideration of Centre for Development of Imaging Technology (herein after referred to as C-DIT, which expression shall unless repugnant to the context or meaning thereof include its successors, administrators and assigns) having awarded to M/s. with its Registered / Head Office at (herein after referred to as the "Contractor"/which expression shall unless repugnant to the context or meaning thereof, include its successors, administrators, executors and assigns), a contract by issue of C-DIT's letter of intent/Purchase Order No. dated and the same having been unequivocally accepted by the Contractor resulting in a contract, bearing ref. No. dated Valued at.. for and the contractor having agreed to provide a contract performance Guarantee for the faithful performance of the entire contract in lieu of Cash/Security Deposit equivalent to 5% (five percent) of the said value of the Contract to C-DIT.

We the Bank (Name & Address) having our Head Office at (hereinafter referred to as the "Bank", which expression shall, unless repugnant to the context or meaning thereof, include its s, administrators, executors and assigns) do hereby guarantee and undertake to pay the C-DIT, on demand any and all moneys payable by the Contractor to the extent of as aforesaid at any time upto** (days/month/year) without any demur, reservation, contest, recourse or protest and/or without any reference to the contractor. Any such demand made by the C-DIT on the Bank shall be conclusive and binding notwithstanding any difference between the C-DIT and the Contractor or any dispute pending before any Court, Tribunal, Arbitrator or any other authority. The Bank undertakes not to revoke this guarantee during its currency without previous consent of the C-DIT and further agrees that the guarantee herein contained shall continue to be enforceable till the C-DIT discharges this guarantee.

The C-DIT shall have the fullest liberty without affecting in any way the liability of the Bank under this guarantee, from time to time, to extend the time for performance on the contract by the contractor. The C-DIT shall have the fullest liberty, without affecting this guarantee, to postpone from time to time the exercise of any powers vested in them or of any right which they might have against the Contractor and to exercise the same at any time in any-manner, and either to enforce or forbear to enforce any covenants, contained or implied, in the

contract between the C-DIT and the Contractor or any other course or remedy or security available to the owner. The bank shall not be released of its obligations under these presents by any exercise by the C-DIT of its liberty with reference to the matters aforesaid or any of them or by reason of any other act or forbearance or other acts of omission or commission on the part of the C-DIT or any other matter or thing whatsoever which under law would, but for this provision have the effect of relieving the Bank.

The Bank also agrees that the C-DIT at its option shall be entitled to enforce this guarantee against the Bank as a Principal debtor in the first instance without proceeding against the Contractor and notwithstanding any security or other guarantee that the C-DIT may have in relation to the contractor's liabilities.

Notwithstanding anything contained herein above our liability under this guarantee is restricted to and it shall remain in force up to and including.. and shall be extended from time to time for such period (not exceeding one year) as may be desired by M/s. on whose behalf this guarantee has been given :

Dated this day of 200 -
..... at

(Signature)
(Banker's Rubber Stamp)

WITNESS

(Signature).
(Name).

(Name) (Designation with Bank stamp)

(Official Address) Attorney as per power of
..... Attorney No.
.....

Date

Notes:

The Stamp papers of appropriate value shall be purchased in the name of Guarantee issuing Bank.

**The date will be the expiry date of the guarantee period as specified in the Contract.

ANNEXURE III
PROFORMA OF "AGREEMENT"
(To be executed on non-Judicial Stamp Paper)

This Agreement made this. day of Two thousand and Between Centre for Development of Imaging Technology, a Society, registered under the Travancore-Cochin Literary, Scientific and Charitable Societies Registration Act XII of 1955, having its registered Office at Chitranjali Hills, Thiruvallom, Trivandrum 695 027 (hereinafter referred to as "C-DIT" which expression shall include its administrators, successors, executors and assigns) of the one part and a company/firm incorporated under the.. having its registered Office at (hereinafter referred to as the "Contractor" or "X" (brief name of contracting Co.) (which expression shall include its administrators, successors, executors and permitted assigns) of the other part.

WHEREAS C-DIT has invited bids for (briefly describe scope of the (work) as per its specification Ref. No.

AND WHEREAS..... "X" had participated in the above referred bidding vide their proposal No. dated and C-DIT accepted their aforesaid proposal and awarded the dated and C-DIT accepted their aforesaid proposal and awarded the contract to. "X" on terms and conditions contained in its letter of Indent/Purchase Order No. dated And the

documents referred to therein, which have been accepted by "X"
..... resulting into a "Contract"

NOW THEREFORE THIS DEED WITNESSETH AS UNDER :-

Article 1.0 AWARD OF CONTRACT

C-DIT has awarded the contract to "X"
..... for the work of on the
terms and conditions contained in its letter of Indent/Purchase Order No.
..... dated and the
documents referred to therein. The award has taken effect from.
.....i.e. the date of issue of the aforesaid Letter.
The terms & expressions used in this Agreement shall have the same meaning as
are assigned to them in the "Contract Documents" referred to in the succeeding
Article.

Article 2.0 CONTRACT DOCUMENTS

The Contract shall be performed strictly as per the terms and conditions
stipulated herein and in the following documents attached herewith (hereinafter
referred to as "Contract Documents").

Article 3.0 CONDITIONS & CONVENANTS

The scope of Contract, Consideration, Terms of payment, price Adjustment,
Taxes wherever applicable, Insurance, liquidated Damages, performance,
Guarantee and all other terms and conditions are contained in C-DIT's Purchase
Order No. dated read in conjunction
with other aforesaid Contract documents. The Contract shall be only performed
by the Contractor strictly and faithfully in accordance with the terms of the
Agreement.

The scope of work shall also include supply and installation of all such items
which are not specifically mentioned in the contract Documents, but which are
needed for successful, efficient, safe & reliable operation of the equipment unless
otherwise specifically excluded in the specifications under "exclusions" or
Purchase Order.

TIME SCHEDULE: Time is the essence of the contract and schedules shall be
strictly adhered to. "X" shall perform the work in accordance with the agreed
schedule as given in letter of Indent/Purchase Order.

The Contractor guarantees that the equipment package under the contract shall meet the ratings and performance parameters, as stipulated in the Technical Specifications (Volume II) and in the event of any deficiencies found in the requisite performance figures, the C-DIT may at its option reject the equipment package or alternatively accept it on the terms and conditions and subject to levy of the liquidated damages in terms of Contract Documents. The amount of liquidated damages so leviable shall be in accordance with the Contract Documents and without any limitation.

It is further agreed by the Contractor that the Contract performance Guarantee shall in no way be construed to limit or restrict the C-DIT's right to recover the damages/compensation due to short-fall in the equipment performance figures as stated in para 3.4 above or under any other clause of the Agreement. The amount of damages/Compensation shall be recoverable either by way of deduction from the contract price, contract performance guarantee and/or otherwise.

The Contract performance Guarantee furnished by the Contractor is irrevocable and un-conditional and the C-DIT shall have the powers to invoke it notwithstanding any dispute or difference between the C-DIT and the contractor pending before any court, tribunal, arbitrator or any other authority.

This Agreement constitutes full and complete understanding between the parties and terms of the presents. It shall supersede all prior correspondence to the extent of inconsistency of repugnancy to the terms and conditions contained in the Agreement. Any modification of the Agreement shall be effected only by a written instrument signed by the authorised representatives of both the parties.

Article 4.0 SETTLEMENTS OF DISPUTES

It is specifically agreed by and between the parties that all the differences or disputes arising out of the Agreement or touching the subject matter of the Agreement shall be decided by process of settlement & Arbitration as specified in clause.. and of the conditions of the contract and the provisions of the Indian Arbitration Act, 1940 shall apply and Kerala Courts alone shall have exclusive jurisdiction over the same.

NOTICE OF DEFAULT

Notice of default given by either party to the other party under the Agreement shall be in writing and shall be deemed to have been duly and properly served upon the parties here to if delivered against acknowledgement or by telex or by

registered mail with acknowledgement due addressed to the signatories at the addresses mentioned hereinabove.

IN WITNESS WHEREOF, the parties through their duly authorised representatives have executed these presents (execution where of has been approved by the competent authorities of both the parties) on the day, month and year first above mentioned at Trivandrum.

WITNESS

C-DIT

1.

(Signature)
(Name)

2.

(Designation)
(Seal)

1.

(Contractors signature)
(Designation)
(Seal)

2.